



Yanmar Series

Specification & Application Data



Generator depicted with sound attenuated option, some accessories for display only.

60Hz Power Ratings kW (kVA)

Voltage VAC	Phase	PF	Standby		Prime	
			kW	kVA	kW	kVA
120/240	1	1	33	33	30.7	30.7
120/208	3	N/A	N/A	N/A	N/A	N/A
120/240 Delta	3	N/A	N/A	N/A	N/A	N/A
277/480	3	N/A	N/A	N/A	N/A	N/A
347/600	3	N/A	N/A	N/A	N/A	N/A

Rating Definitions: (N/A = Not available for model designated)

Standby - All Industrial Sets are Standby Rated, applicable for a varying emergency load for the duration of a utility power outage with no overload capability. Alternator winding temperature rise is 150°C. (125°C prime rated)

Prime - Prime rating is applicable for supplying power to a varying load in lieu of utility for an unlimited amount of running time. (Max. load factor = 80%) A 10% overload capacity is available for 1 out of every 12 hours.

Overview of the HIPOWER® Yanmar series of Industrial Generator Sets:

HIPOWER® Industrial generators are factory-built in facilities that utilize the latest technology in sheet metal fabrication, mechanical and electrical component assembly, production and testing.

Each model is the result of computer aided design and modeling backed up by exhaustive prototype-testing. Our development technology results in a unique range of innovative designs for highly reliable generator sets backed-up by a limited warranty covering all components.

Standard Configuration of Industrial Sets:

- **Yanmar:** Long-life, heavy-duty, 4-cycle, direct injection engine from a world renown manufacturer for economy of operation and maximum reliability and durability. Capable of full rated load acceptance in one step.
- **Cooling:** Radiator with belt driven pusher fan.
- **Filtration:** Heavy duty replaceable element air-cleaner
- **Alternator:** Single bearing, 4-pole, rotating field, self-excited, self-ventilated, 12-wire re-connectable, 60Hz brushless alternator with Class H insulation. Automatic voltage regulator (AVR) providing close voltage regulation.
- **Certification:** Generator set is CSA certified and meets ISO 8528-5.
- **Arrangement:** Open skid with engine and alternator units closed coupled together and with resilient anti-vibration isolators mounted between the assembly and a heavy-duty steel base. The sturdy base frame has openings allowing for winching, slinging and forklift pockets for ease of handling
- **Auto Start Control Panel:** Digital auto-start microprocessor based control panel with remote start capability.
- **Starting System:** 12 volt starter motor, battery cables, battery and belt driven charging alternator.

Standard Features of Industrial Sets:

- HIPOWER® is a single source for all the generator system
- Generators are produced in a facility dedicated to generator set manufacture
- The generator set can accept rated load in one step
- 2 years or 1000 hours limited warranty given as standard. Extended warranties offered as options to the standard
- Base set meets NFPA 110, Level 1, when accessorized with the required equipment and installed per NFPA standards
- Test certificates available for the fully factory tested industrial generator sets
- HIPOWER® generator sets are designed to fit a full range of options for complying with many diverse applications
- Full range of safety features to ensure full protection of the generator system. (See back-page for details).



Application & Specification Data

Industrial Generator Set Specification:

Governor regulation class	ISO 8528 Part1 Class G3
Voltage regulation, no load to full load	+/- 1%
Frequency regulation	Isochronous
Radio frequency emissions compliance	Meets requirements of most industrial & commercial applications
skVA@30% voltage dip (240 volts)	54
Main line circuit breaker - amps capacity 240V	150

Engine Specification:

Manufacturer	Yanmar
Model	4TNV98 ZGGEH
EPA certified	Tier 4i
Crankshaft speed	1,800 rpm
Type	Industrial, four stroke
Injection	Direct
Aspiration	Natural
Number of Cylinders	4
Cylinder arrangement	In-line
Displacement CID (liters)	202.5 (3.319)
Bore and Stroke ins (mm)	3.85 X 4.33 (98 X 110)
Nominal power	46.1 hp
Cooling	Liquid
Governor	Electronic
Starting motor & alternator	12 volt
Compression ratio	18.5:1
Air cleaner type	Dry - light duty, single stage
Exhaust gas flow cu. ft./minute (cu. /minute)	371.1 (10.51)
Max. Exhaust temp at full load degrees °F (°C)	1067 (575)
Max. permissible back pressure - ins H ₂ O (kPA)	51.2 (12,75)

Cooling System:

Engine cooling air flow - cu. ft./second (cu. m/second)	41.53 (1.176)
Alternator cooling flow - cu. ft./second (cu. m/second)	5.66 (0.165)
Total cooling air flow (engine + alternator + combustion)	48.95 (1.386)
Total cooling capacity - US gallons (liters)	2.37 (9)

Lubrication system:

Oil pan capacity - US gallons (liters)	2.5 (9.5)
Oil pan capacity with filter - US gallons (liters)	2.7 (10.2)
Oil cooler	Water - cooled
Recommended lubricating oil grade	SAE 10W30 - API (CF, CF-4, CI-4)
Oil consumption at full load	0.14% of fuel
Oil pressure - psi (kPA)	48.35 (333.3)

Engine Electrical System:

Starting motor voltage	12 volt
Battery capacity	70 amps
Cold Cranking Amps - minimum	770 amps

Fuel System:

Recommended fuel	# 2 Diesel - ULSD
Fuel supply line, min. ID in. (mm)	0.19 (9)
Fuel return line, min. ID in. (mm)	0.19 (9)
Max. lift, fuel pump, type, ft (m)	6 (1.85)
Fuel filter	Replaceable element

Fuel consumption:

	Standby Power Rating	Prime Power Rating
100% load – US gallons/hour	2.86	2.57
75% load - US gallons/hour	2.1	1.93
50% load - US gallons/hour	1.46	1.45
25% load - US gallons/hour	1.15	1.09

Alternator Specification:

Manufacturer	Stamford
Model	PI 144 K
Voltages	1-phase 120/240
Alternator Type	4-pole, rotating field
Excitation System	Brushless, self-exciting
Power factor	1
Number of leads	12
Stator Pitch	2/3
Insulation	Class H
Windings – Temperature Rise	125° C
Enclosure (IEC-34-S)	IP 23
Bearing	Single, sealed
Coupling	Flexible disc
Amortisseur windings	Full
Voltage regulation – no load to full load	plus or minus 1%
TIF	< 50
Line harmonics	5% maximum

Standard Features: *(see back-page for control panel details)*

● Radiator with pusher fan	● Standard fuel filter
● Medium - duty, two-stage dry element	● All rotating components (i.e. fan) protected with metal guards
● Heavy-duty engine start batteries in rack with cables	● All hot components (i.e. exhaust) protected with metal guards
● External emergency stop switch	● Ground connection prepared for ground spike (not supplied)
● Control Panel M6 (See over for details)	● Main line ABB UL listed circuit breaker for overload protection
● Oil drain extension	● Operation and installation literature
● Steel base for mounting on fuel tank and/or concrete surface	● CSA certified

Available Options:

<input type="checkbox"/> Sound attenuated canopy with rock-wool insulation, silencer, rounded corners for rigidity and weather protection & stainless steel fixtures			
<input type="checkbox"/> Electric actuator & louvers for air intake and exhaust (for above)	<input type="checkbox"/> Alternator anti-condensation heaters		
<input type="checkbox"/> Residential silencer -35dBA (for open skid only)	<input type="checkbox"/> Murphy oil make-up tank 2 or 4 gallon		
Fuel Tank Options:	<input type="checkbox"/> 12-hr non-UL	<input type="checkbox"/> 24-hr non-UL	<input type="checkbox"/> 24-hr UL142
<input type="checkbox"/> Static battery charger 3A non-UL	<input type="checkbox"/> Static battery charger 5A or 10A UL		
<input type="checkbox"/> Engine block heater	<input type="checkbox"/> Control panel heater		
<input type="checkbox"/> Racor water-separator filter	<input type="checkbox"/> Battery blanket		
<input type="checkbox"/> PMG AVR for Stamford Alternator only	<input type="checkbox"/> Remote annunciator		
Auto Transfer Switch (ATS) Options:	<input type="checkbox"/> Open transition ATS	<input type="checkbox"/> Closed transition ATS	
	<input type="checkbox"/> Delayed transition ATS	<input type="checkbox"/> Service entrance ATS	

HIPOWER CEM7 Control Panel: Hipower model CEM7 digital controller with auto and manual start capability. Digital readout for: volts between each phase & neutral, volts between phases, amps per phase, frequency, kW and kVA power, power factor, KW hour with accumulation by day, month and year, fuel reserve, oil pressure, coolant temperature, battery volts and charging alternator volts, engine speed, hours running. Engine alarms for high coolant temperature, low oil pressure, emergency stop activated, battery charging failure, low coolant level, low fuel level, over-speed, under-speed and low battery volts.

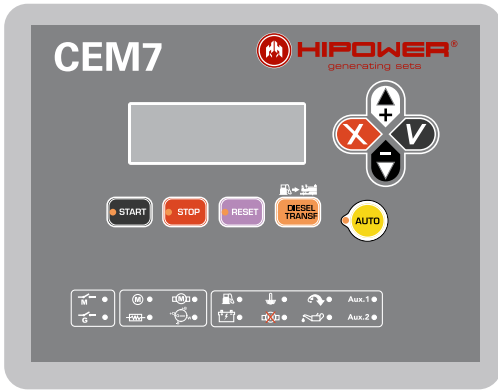

Alarms for over-load, unbalance voltage, over-volts, under-volts, over-frequency, under-frequency, short circuit, inverse power and incorrect phase sequence. The CEM7 controller has an internal digital hour recorder.

Also included in Hipower's supply: Emergency stop button and mainline circuit breaker.

Pictures of Control Panel RH and Controller LH may include optional equipment and/or accessories



Model HYW 35 M6 Enclosed Set

key dimensions and sound levels

LEFT SIDE VIEW

FRONT VIEW

RIGHT VIEW

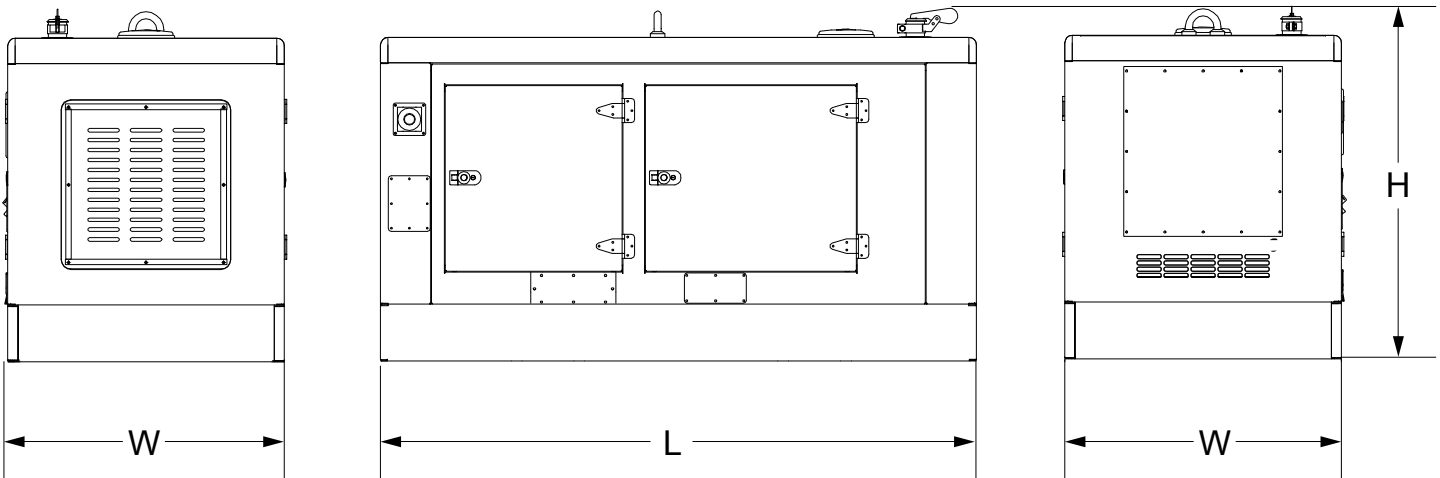

Configuration	Fuel Tank Data (base option)		Generator Data *				
	Run Time Hours	Capacity (Gals)	L = Length	W = Width	H = Height	Weight lbs	dBa
Enclosed Set (as diagram)	9.26	26.4	82.6"	38.4"	49.2"	2315	63
Open Set (not shown)	TBA	TBA	65.6"	31.9"	47.0"	1276	TBA

* All measurements are approximate and for estimation purposes only. Weights are without fuel tank. Sound levels measured at 23ft (7m) and does not account for ambient site conditions.

Codes and Standards Compliances used where applicable



Renting. So smart, so easy.



- NFPA 99
- NFPA 110
- ISO 8528-5
- ISO 1708A.5
- ISO 3046
- BS5514
- SAE J1349
- DIN6271
- IEE C62.41 TESTING
- NEMA ICS 1

your partner for power™

© 2012 HIPOWER® Systems Inc. All rights reserved. HIPOWER® is a registered trademarks of Himoina Power Systems, Inc.. HIMOINSA® is a registered trademark of Himoina SL. Other company, product, or services names may be trademarks or service mark of others. Specifications are subject to change without notice.

HIPOWER®
your partner for power

Ref# 666-10040-October 2012